

# Presentation to the Parliamentary Portfolio Committee of Transport (PCOT) –

## Update on security related incidents at OR Tambo International Airport

02 AUGUST 2017

- ↑ Terminals
- ↑ Toilets
- ↑ Banks
- ↑ Shops



**O.R. TAMBO**  
INTERNATIONAL AIRPORT  
AIRPORTS COMPANY SOUTH AFRICA

# CONTENTS

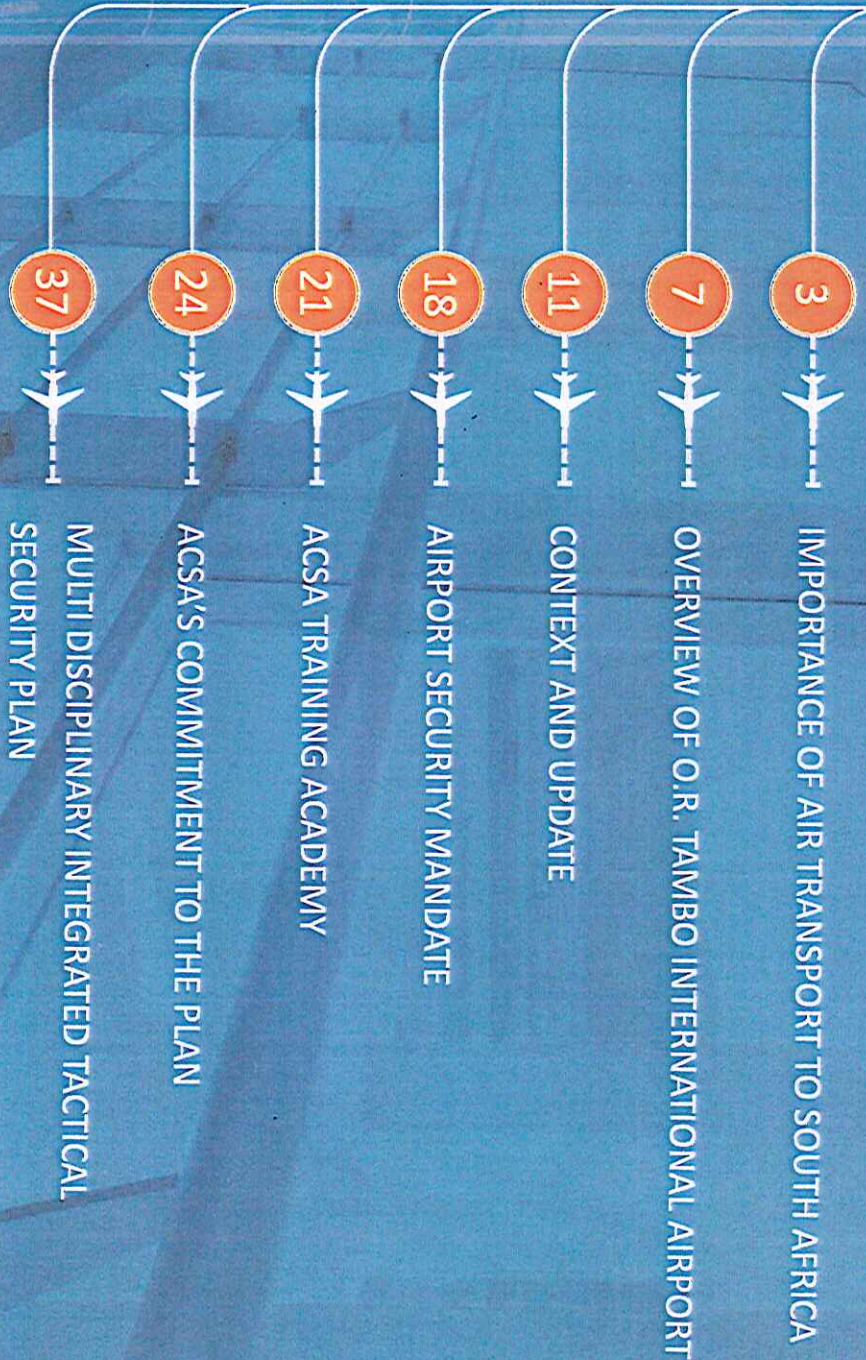

3	IMPORTANCE OF AIR TRANSPORT TO SOUTH AFRICA
7	OVERVIEW OF O.R. TAMBO INTERNATIONAL AIRPORT
11	CONTEXT AND UPDATE
18	AIRPORT SECURITY MANDATE
21	ACSA TRAINING ACADEMY
24	ACSA'S COMMITMENT TO THE PLAN
37	MULTI DISCIPLINARY INTEGRATED TACTICAL SECURITY PLAN



# IMPORTANCE OF AIR TRANSPORT TO SOUTH AFRICA



# IMPORTANCE OF AIR

## TRANSPORT TO SOUTH AFRICA

The air transport sector makes a major contribution to the South African economy

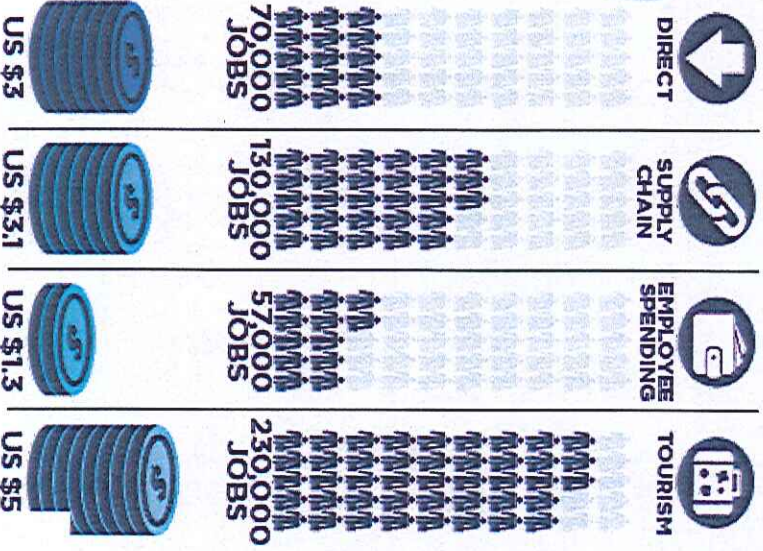
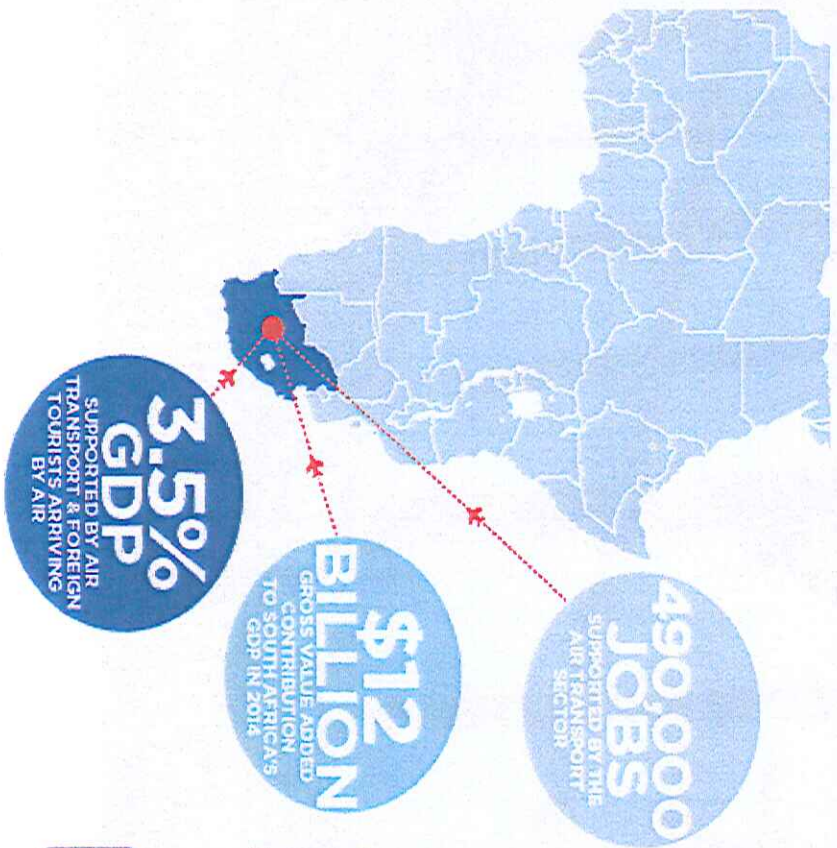

BILLION GROSS VALUE ADDED



# IMPORTANCE OF AIR

## TRANSPORT TO SOUTH AFRICA

**7** AIRPORTS COMPANY SOUTH AFRICA **5**

**Air transportation facilitates exports, foreign direct investment, and tourism**

The ten most popular direct flight links:

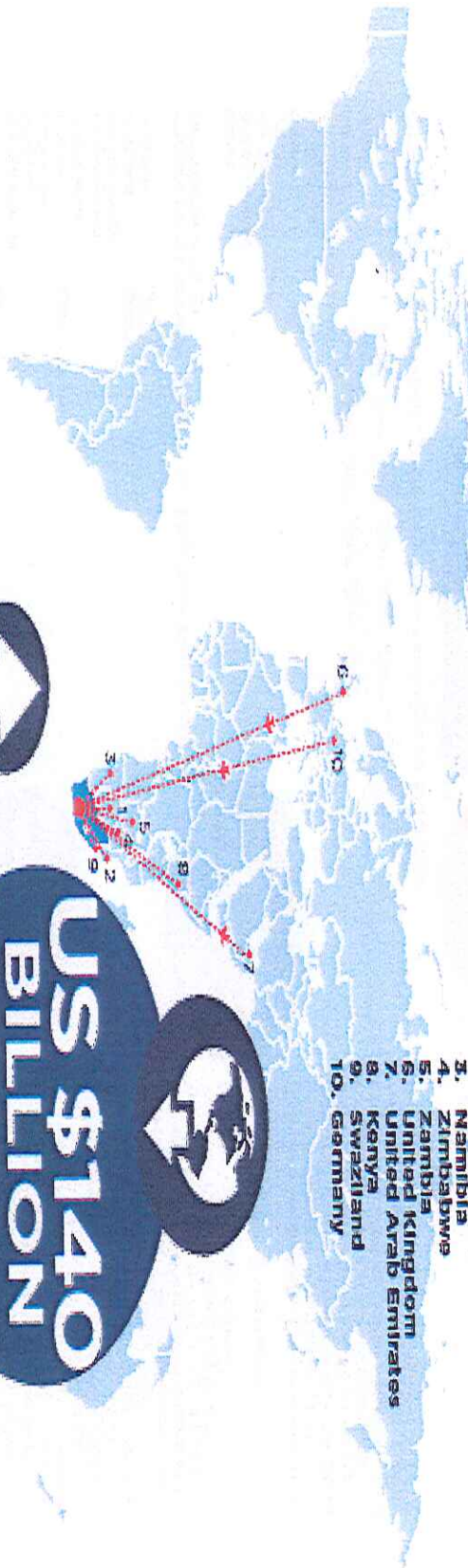

**US \$92 BILLION**  
FOREIGN EXPENDITURE

**US \$110 BILLION**  
EXPORTS

**US \$140 BILLION**  
FDI

The scale of investment, exports, and inbound spending in South Africa

Air transport brings tourists and investment into South Africa, and helps businesses trade their goods and services around the world. In 2014, foreign tourists

spent US \$92 billion in South Africa, supporting restaurants, hotels, transport providers, and others who cater to tourists. In addition, South Africa exported US \$110 billion worth of goods and services in 2014. Over time, the country has accumulated US \$140 billion in foreign direct investment.



# IMPORTANCE OF AIR TRANSPORT

## TO SOUTH AFRICA

7

AIRPORTS COMPANY SOUTH AFRICA

6

### The air transport sector connects people around the world

Number of direct flight destinations in the ten fastest growing countries

- India
- Bangladesh
- Vietnam
- Pakistan
- China
- Indonesia
- Philippines
- Kazakhstan
- Angola
- Nigeria

4 DIRECT FLIGHT DESTINATIONS IN THE TEN FASTEST GROWING COUNTRIES

20 DIRECTLY WEEKLY FLIGHTS TO THE TOP 10 FASTEST GROWING CITIES

Number of direct flights to the top ten fastest growing cities

- Surat
- Ahmedabad
- Ho Chi Minh city
- Hà Nội
- Delhi
- Bengaluru
- Hyderabad (India)
- Khrushaba
- Dhaka
- Lagos

Arrivals by continent, number of passengers (000s)

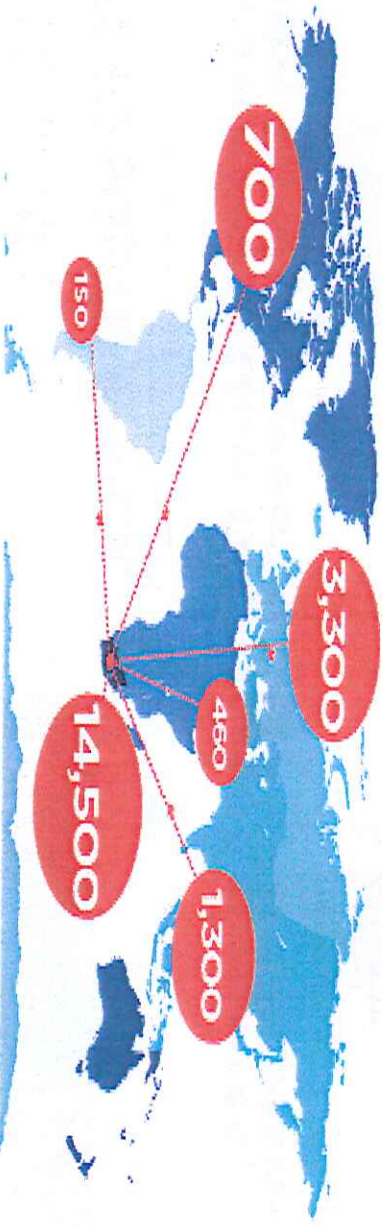

The air transport sector's ability to connect South Africa to emerging countries and fast growing cities can help drive economic growth. There are 4 direct flight destinations among the ten fastest growing countries in the world as measured by GDP growth and 8 direct flight destinations among the 20 fastest growing countries. There are 20 direct weekly flights among the ten fastest growing cities in the world as measured by GDP growth and 43 direct weekly flights among the 100 fastest growing cities.<sup>1</sup>

**Arrivals by continent**  
Europe and Asia-Pacific are the largest sources of arrivals to South Africa after Africa. In 2014, 3.3 million passengers arrived to South Africa from Europe (16.3 percent of the total) and 1.3 million passengers arrived from Asia-Pacific (6.5 percent).



OXFORD ECONOMICS

<sup>1</sup> Fastest growing countries are measured by Oxford Economics for countries that GDP growth 2013-2015, with a threshold of 5% or higher. GDP, fastest growing cities are ranked by Global Growth Cities Index 2013-2015 with a threshold of 10% or higher.



# OVERVIEW

# O. R. TAMBO INTERNATIONAL AIRPORT



# AFRICA'S BUSIEST

## AIRPORT

*Serving the commercial hub of Africa, O.R. Tambo International hosts over 90% of all the airline passengers in South Africa.*

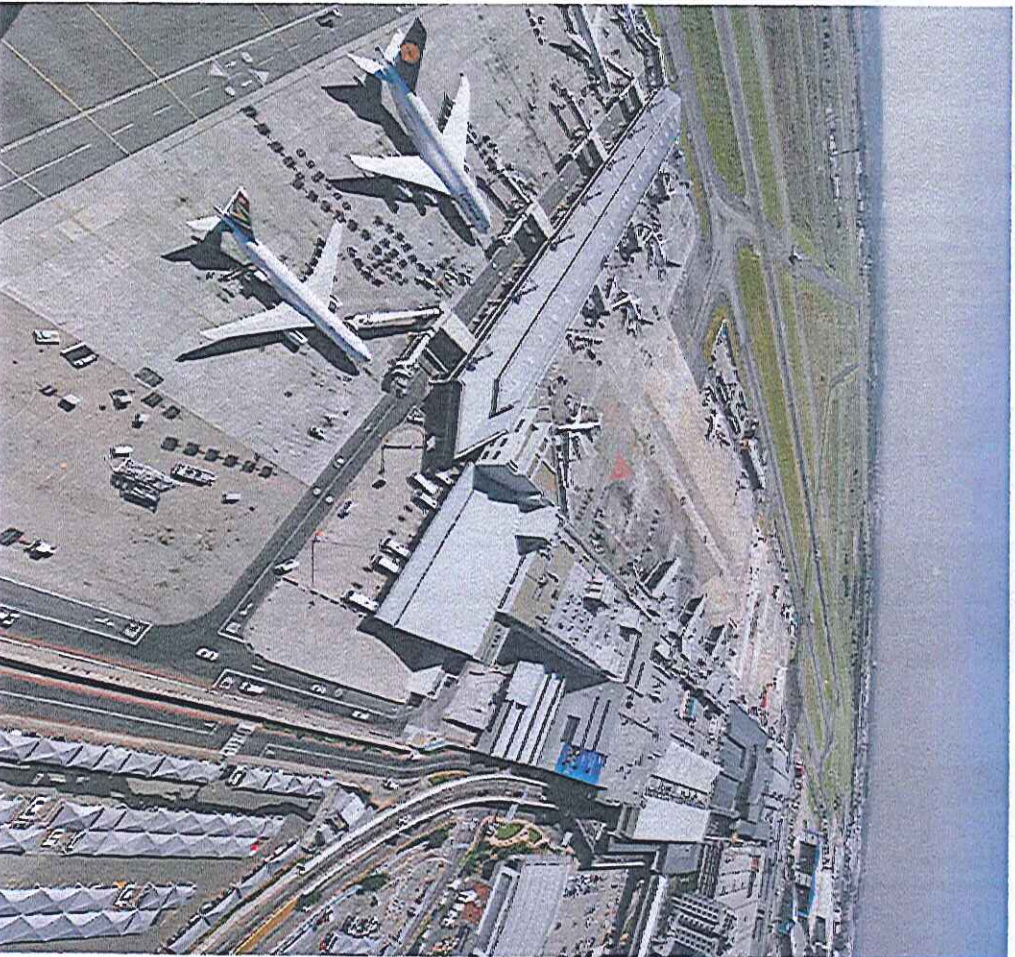

AIRPORTS COMPANY SOUTH AFRICA

8

**20 374 998**

Passenger throughput

**224 191**

Total air traffic movements

**32 945**

International flight departures

**42**

Airlines – 32 International

**53**

Hourly runway capacity

**28 000 000**

Annual passenger handling capacity

**400 000**

Tonnes of cargo

**35 000**

Employees work at the airport, 1200 ACSA employed

**4 232**

Public parking bays

(For the year to March 2016)



# STRATEGIC LOCATION

## LOCATION

O. R. TAMBO  
AIRPORT CITY



COMPETITIVE  
LOCATION

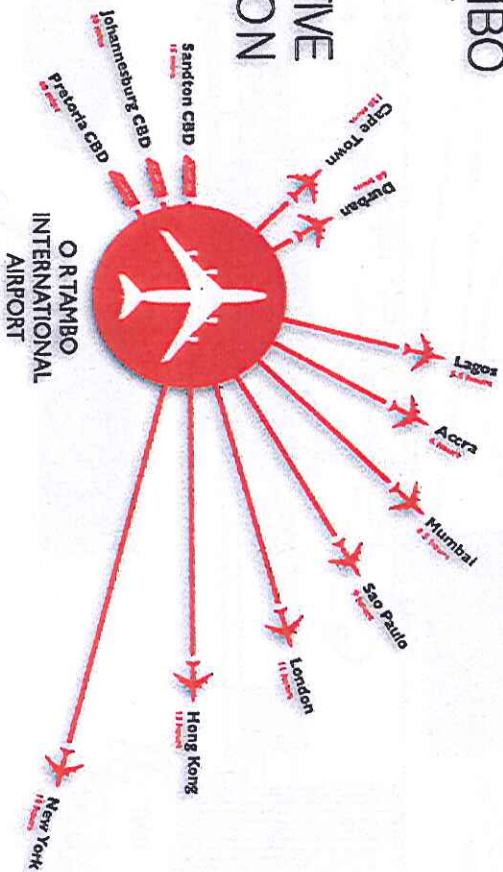

- O.R Tambo is the closest place in South Africa in travel time to the major **global economic centres**.
- O.R Tambo is the closest place in Gauteng in travel time to **other South African cities and African capitals**.
- The **Gautrain, R21 and R24 highways** connect O.R Tambo locally and regionally.

# AIR TRANSPORTATION SYSTEM

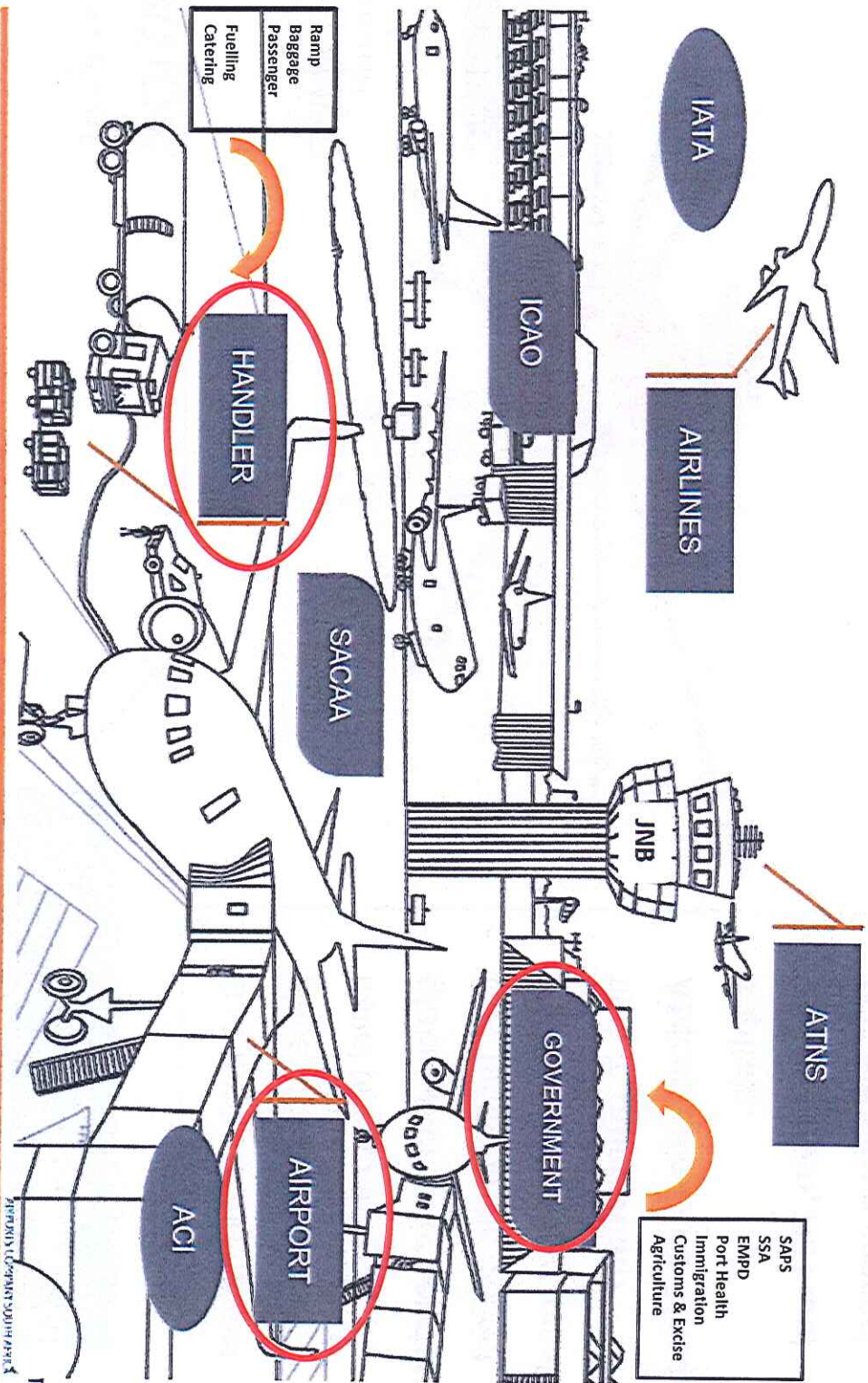

11



# CONTEXT AND UPDATE

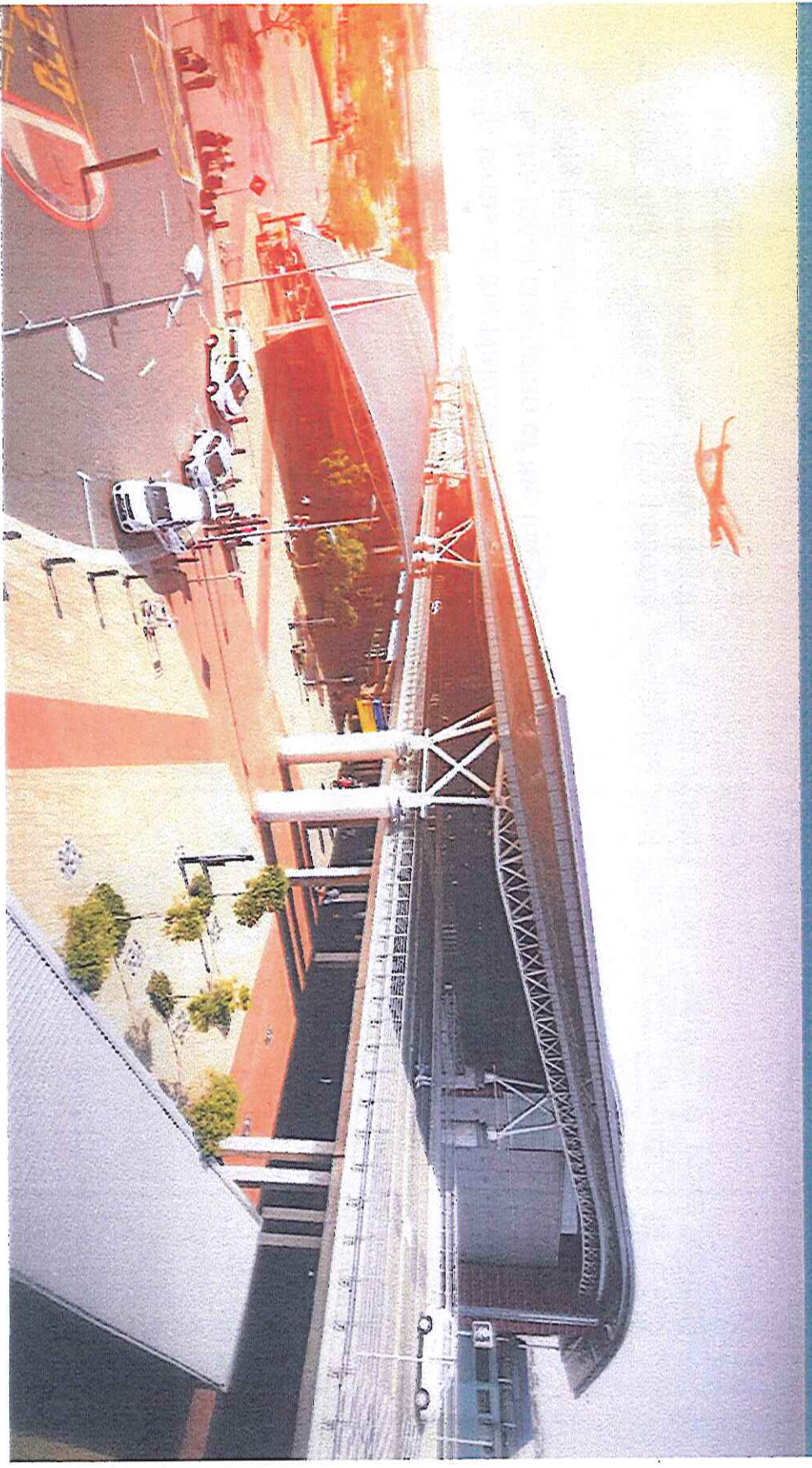



## OVERVIEW

- In the past two years, the safety and security of passengers, airport community, airport service providers and the public at O.R. Tambo International Airport has been on a decline, culminating in a high number of reported criminal incidents.
- In terms of the National Key Point Act (NKP), the South African Police Service (SAPS) is the legal custodian of the integrity of O.R. Tambo International Airport as a strategic state installation.
- The major lapses in the policing measures and the serious escalation of crime experienced over as many months at the Airport level required a more serious intervention.
- On 30 May 2017, a letter which outlined Airport Management concerns and frustrations, was sent to the then Acting Commissioner of Police, LT-General Kgomotso Phahlane
- The matter was subsequently escalated directly to the Minister of Police, Hon. Minister Fikile Mbalula, following the suspension of LT General Phahlane.
- On 06 June 2017, ACSA Executives met with the Minister of Police, Hon. Minister Fikile Mbalula

# SUMMARY OF INCIDENTS

## OVER THE PAST 10 MONTHS



Date	Summary of Incident
<b>12 October 2016</b> (approximately 23h57)	African Freight Services (AFS) was robbed of a consignment of cell phones by armed men dressed as Police officers.
<b>21 October 2016</b> (approximately 09h13)	Big Five Duty Free employees were robbed of an undisclosed sum of money inside the main passenger terminal building.
<b>08 November 2016</b> (approximately 18h55)	Armed suspects using a Bid-Air vehicle gained access onto Airside via North Gate 1 and allegedly hijacked a Bid-Air operational vehicle.
<b>27 November 2016</b> (approximately 18h15 )	A Hawks officer and a Police officer allegedly shot and killed each other near Super South Gate.
<b>07 March 2017</b> (approximately 19h23)	An armed robbery took place on Airside. It is alleged several men dressed in police uniforms held up Reshebie security guards stationed at North Gate 1 and drove onto Airside where they stole R 20 000 000 destined for the United Kingdom.

# SUMMARY OF INCIDENTS

## OVER THE PAST 10 MONTHS



Date	Summary of Incident
01 April 2017	A cash in transit vehicle was blown up with explosives on R24, close to Barbara Road off ramp, four kilometres away from the airport.
15 May 2017 (approximately 16h15)	A hijacking and murder took place on the ring road of the airport. It is alleged that suspects stopped traffic and shot the driver of a H1 Hyundai in execution style.  The vehicle with six passengers inside was hijacked and later found abandoned in Kempton Park. This incident took place 500 metres away from the airport's main passenger terminal building.
04 June 2017 –	Perishable cargo armed robbery
01 July 2017	Swissport foiled warehouse armed robbery
10 July 2017	Armed robbery of a truck containing valuable goods coming from the Airport
15 July 2017	Follow-home from Airport to Bedfordview. Armed suspects held up Uber driver and passenger. Goods to the alleged value of R70,000 taken. No injuries. SAPS continue to investigate the incident.

# Crime at OR Tambo gives Mbalula 'sleepless nights'

BABALONDENZE

**POLICE** Minister Fikile Mbalula told MPs they "would collapse" if they were to know the full extent of crime at OR Tambo International Airport.

Appearing before the police portfolio committee yesterday, Mbalula painted a grim picture of crime at South Africa's busiest airport, which is also a national key point. He said the crime at the airport gave him sleepless nights.

Mbalula said he had now asked the new acting national police commissioner, Lesetja Motlaha, to treat law security at OR Tambo airport as a matter of urgency.

"Where police are erring, we need to act on that. We are not only concerned about police corruption and docket disappearance but the recycling of criminals in the system.

"Our approach is more operational. Yesterday, before I came here, I went to SAA (at OR Tambo), our national key point. I didn't sleep, I didn't sleep, I can tell you. And I immediately talked to the general.

"We need to look at that. If you had to know what is happening there, you would collapse," said Mbalula.

The airport has had several security breaches recently, despite a highly visible police presence because it is a national key point.

The most prominent security breach this year was a brazen cash heist in March when millions of rands were stolen from the cargo area, allegedly with the help of some police officers.

Formally introducing Motlaha to MPs since his acting appointment by President Jacob Zuma last week, Mbalula said that poor security at OR Tambo would no longer be an end on

## Couple shot, robbed at Joburg hotel

Man, wife shot after arriving from the airport

By Phisofo Mphahlele

Centre of Justice and Equality Reporting on the police portfolio committee yesterday, Mbalula said that poor security at OR Tambo International Airport was a national key point.

"The car had just entered the hotel at about 10am when the couple was shot. They were driving to the airport. The couple was shot in the back of the car. The couple was shot in the back of the car. The couple was shot in the back of the car.

"The car had just entered the hotel at about 10am when the couple was shot. They were driving to the airport. The couple was shot in the back of the car. The couple was shot in the back of the car.

Police Minister Fikile Mbalula is worried by the rising number of robberies and shootings happening to people travelling from OR Tambo International Airport. (EPA/ALAMY)

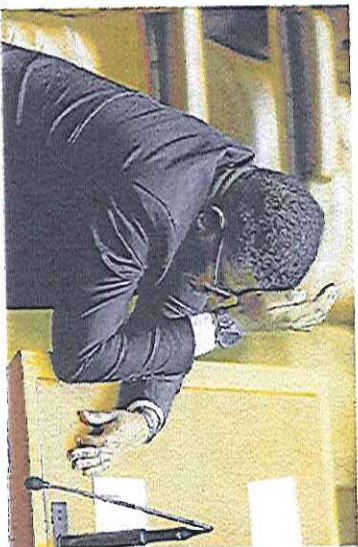

# Thugs following people from airport a big worry

LANIT CHERNICK  
lanit.chernick@nl.co.za

THE Airports Company South Africa (Acsa) has voiced concern over the spate of serious crime incidents at OR Tambo International Airport.

"We are concerned about incidents of crime in the vicinity of the airport and against people followed to their destinations," spokesperson Leigh Gunkel-Krauler said yesterday.

"The safety and security of passengers and visitors to this airport remains of paramount importance to the airport's management.

high level of awareness of these matters in the SAAPS, which is responsible for preventing and investigating crime in and around the airport".

Kamal Shivanand, Acsa's acting senior manager aviation security services, said their mandate

measures are the responsibility of the SAAPS, mandated by the National Key Points Act.

"From a road traffic law enforcement perspective, it's the responsibility of the Ecurtheni metro police department," Shivanand pointed out.

Meanwhile, Uber has confirmed that although the driver affected in Sunday's robbery in Morningside, Sandton, was an Uber driver-partner, he was not on official duty at the time.

"It was a private trip arranged between the passenger and the driver, and not an Uber trip booked via the Uber app."



DREAM RESTAURANT

ETNW

home | advertise | refer a friend | contact us

Meet under THE VIEWS SPECIALS find a conference venue

newswire

Today's News

Advertisement for DREAM RESTAURANT, ETNW, and various services like 'Meet under THE VIEWS SPECIALS' and 'newswire'.

## ISSUES RAISED WITH

### MINISTER MBALULA (6 JUNE)

- Corruption and collusion
- Lack of command and control
- Inadequate resourcing of Government Agencies
- Behaviour and lack of commitment of Government Agencies
- No implementation of sustainable measures
- Non-existence of tactical intelligence
- Poor management of roadways
- Safeguarding of a National Key Point – access control at perimeter gates
- Effectiveness of investigation and prosecution



AIRPORTS COMPANY SOUTH AFRICA

16

Culminated in the development of the Integrated Multi-Disciplinary Tactical Security Plan – launched by Hon. Minister Fikile Mbalula on 21 July 2017



# SUCCESSSES

## TO DATE



AIRPORTS COMPANY SOUTH AFRICA

17

Successes already being recorded based on Integrated Multi-Disciplinary Tactical Security Plan Approach



Date	Summary of Incident
01 July 2017	Folled Swissport warehouse armed robbery
14 July 2017	4 suspects arrested (some brandishing AK47's) in SAPS operation, alleged to be part of follow-home incidents
14 July 2017	Attempted hijacking on two cargo trucks coming out of Guard Force on Griffiths offramp. Tactical unit responded. Trucks were consequently not hijacked
21 July 2017	One suspect arrested outside Emperors Palace linked to follow-home robberies.
22 July 2017	Drug bust - cocaine from Sao Paulo intercepted at the Airport by Customs & Excise. Estimated street value of R7.4m, weighing 26 kilos.
25 July 2017	Rhino horn intercepted in joint operations of SAPS and Customs & Excise at the Airport. It has been established from the preliminary investigations that the suitcase contained 11 pieces of rhino horn weighing approximately 20 kilograms, it arrived from Lusaka, Zambia and was destined for Hong Kong via a SAA flight.

# AIRPORT SECURITY MANDATE





The prevention of acts of unlawful interference to Civil Aviation. (ANNEX 17)

ICAO definition of unlawful interference:

The categories of incidents that should be reported include:

- Unlawful seizure of an aircraft;
- Attempted unlawful seizure of an aircraft;
- Unlawful act against the safety of civil aviation, including acts of sabotage and malicious damage, and the placing of bombs and other explosive devices or substances in airports, aircraft, baggage, cargo or mail;
- Attempted unlawful act against the safety of civil aviation; and
- Any other act of unlawful interference, including armed attacks at airports, acts directed toward off-airport personnel, facilities or vehicles, and acts that have the potential to develop into a threat to international civil aviation.

70,000 per annum

## MANDATE:

### ACSA SECURITY

- Airport protection and access control;
  - Staff and crew screening;
  - Passenger pre-boarding screening;
  - Hold baggage screening;
  - Access control permits;
  - Cyber threats
- Oversight of:**
- Cargo, remote sites and mail operations;
  - Caterers, cleaning companies and other airport tenants;
  - Retailers, hotels and car rental companies;
  - Fuel farms and depots



On December 21, 1988, a suitcase bomb exploded aboard New York-bound Pan Am Flight 103, killing all 259 passengers and crewmembers, along with 11 people on the ground in Lockerbie, Scotland



# AIRPORTS COMPANY SOUTH AFRICA TRAINING ACADEMY

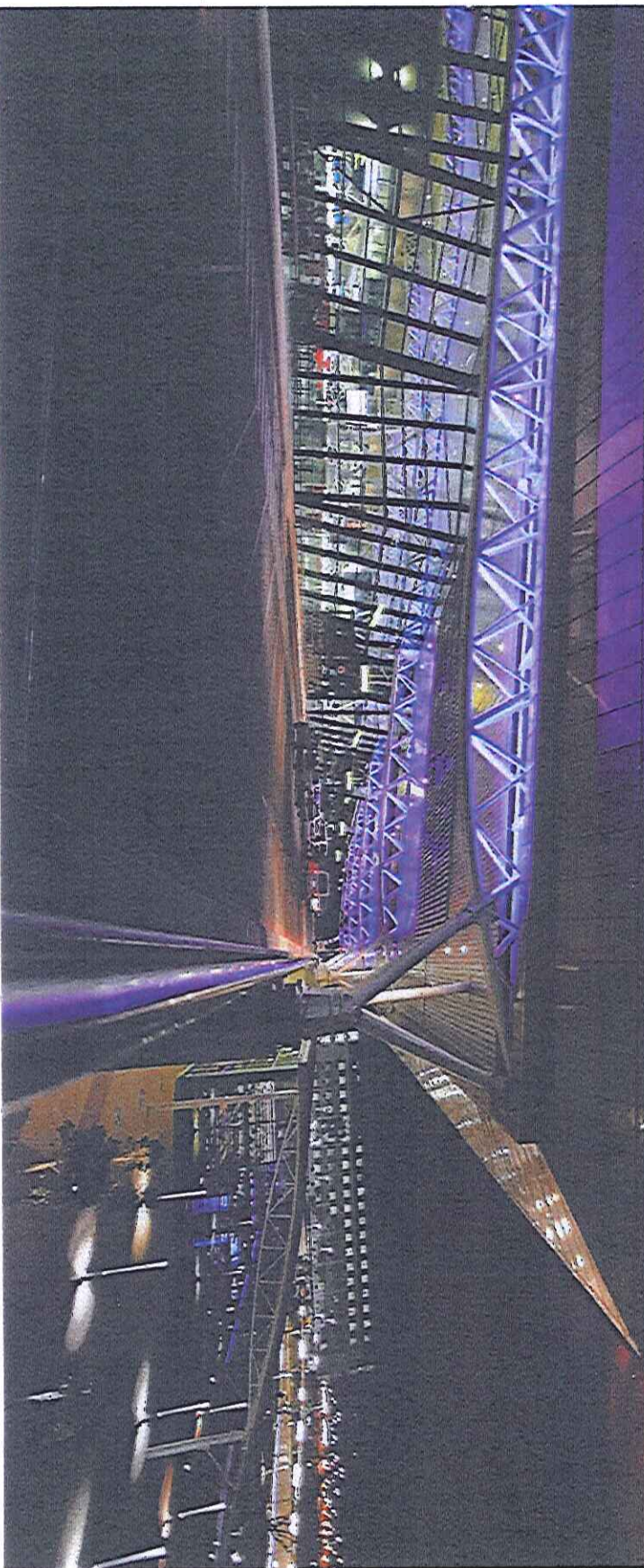

# RECOMMENDED TRAINING FOR STATE AGENCIES



*Airports Company South Africa Training Academy has a 19 year track record of quality aviation training*

Course	Recommended		
	SAPS	DHA	SARS
1. ACSA Basic AVSEC	✓		✓
2. ACSA Supervisor's Course			
3. Security Awareness	✓	✓	✓
4. AIT	✓	✓	✓
5. AVOP	✓	✓	✓
6. Aerodrome Emergency Preparedness	✓		✓
7. ICAO Basic	✓		✓
8. ICAO Crisis Management	✓	✓	✓
9. ICAO Cargo & Mail	✓		✓
10. ICAO Risk Management	✓	✓	✓

## FUTURE

### CONSIDERATIONS

*The Academy is investigating additional training interventions so as to ensure the maintenance of safety and security of its passengers, staff and airport users.*

These include:

1. Behaviour Awareness/Detection – participants learn to assess body language in determining if an individual is a potential threat.
2. Insider Threat – participants learn techniques to determine suspicious behaviour within an organisation.
3. Cyber Security - participants are informed of ways to protect themselves when using electronic devices in the work environment and in protecting sensitive information.
4. Public Security Management – participants understand how the public space is managed within the context of the stakeholders involved at an entity.





# OUR COMMITMENT TO THE PLAN – SHORT TERM AND MEDIUM TERM INTERVENTIONS







## SHORT TERM INTERVENTIONS (3 MONTHS – BY END OF OCTOBER 2017)

*The following short term interventions have been identified and these are based on the needs contained in the integrated tactical plan.*

- **Vetting**
- **Lifestyle audits of all ACCSA staff – phase 1: Supervisor to GM level**
- **Government Agency – Induction & Refresher Training**
  - Orientation of airport
  - Aviation security induction
  - Airside safety induction – including PPE familiarisation
  - Ethics Training
  - PARTAC (Radio licence)
  - Airside Vehicle Operators Permit (AVOP)
- **Formal MOA with all Government Agencies (performance targets – relating to resources and operational performance)**

## SHORT TERM INTERVENTIONS

**(3 MONTHS – BY END OF**

**OCTOBER 2017)**



- **Improved and enhanced Lighting**
  - Our Maintenance Department has been tasked to look at all areas of vulnerability were poor or no lighting exist and remedy the situation.
- **Cameras and Coverage**
  - A security project has been launched were one of the areas to be focused on is cameras. This project will immediately **replace 800 old cameras around the airport from analogue to digital and 4k** ensuring an improved and sustainable view of the various areas of the airport.
- **Airport-wide digitalised radio network**

# GOVERNMENT AGENCIES ACCOMMODATION REQUIREMENTS



AIRPORTS COMPANY SOUTH AFRICA



**INTEGRATED CONTROL  
ROOM OF THE FUTURE  
(BY END MARCH 2018 –  
PARTIAL INTEGRATION)**



## MEDIUM TERM

### INTERVENTIONS (BY END OF

MARCH 2018)



- Implementation of the integrated control room
- Roll-out of licence plate recognition system (LPR)
- Implementation of vehicle intelligence data system
- Roll-out of facial recognition system on the landside of the airport
- Obtain access to SANRAL cameras (including E-Tolls)
- Install transponder system for airside & landside access (cost analysis being done)
- Redesign of cargo access roads, gates and guardhouses

Based on needs  
contained in the  
integrated tactical  
plan

# SMART SECURITY



AIRPORTS COMPANY SOUTH AFRICA

30

By year 2018-19 - all 6 in Domestic

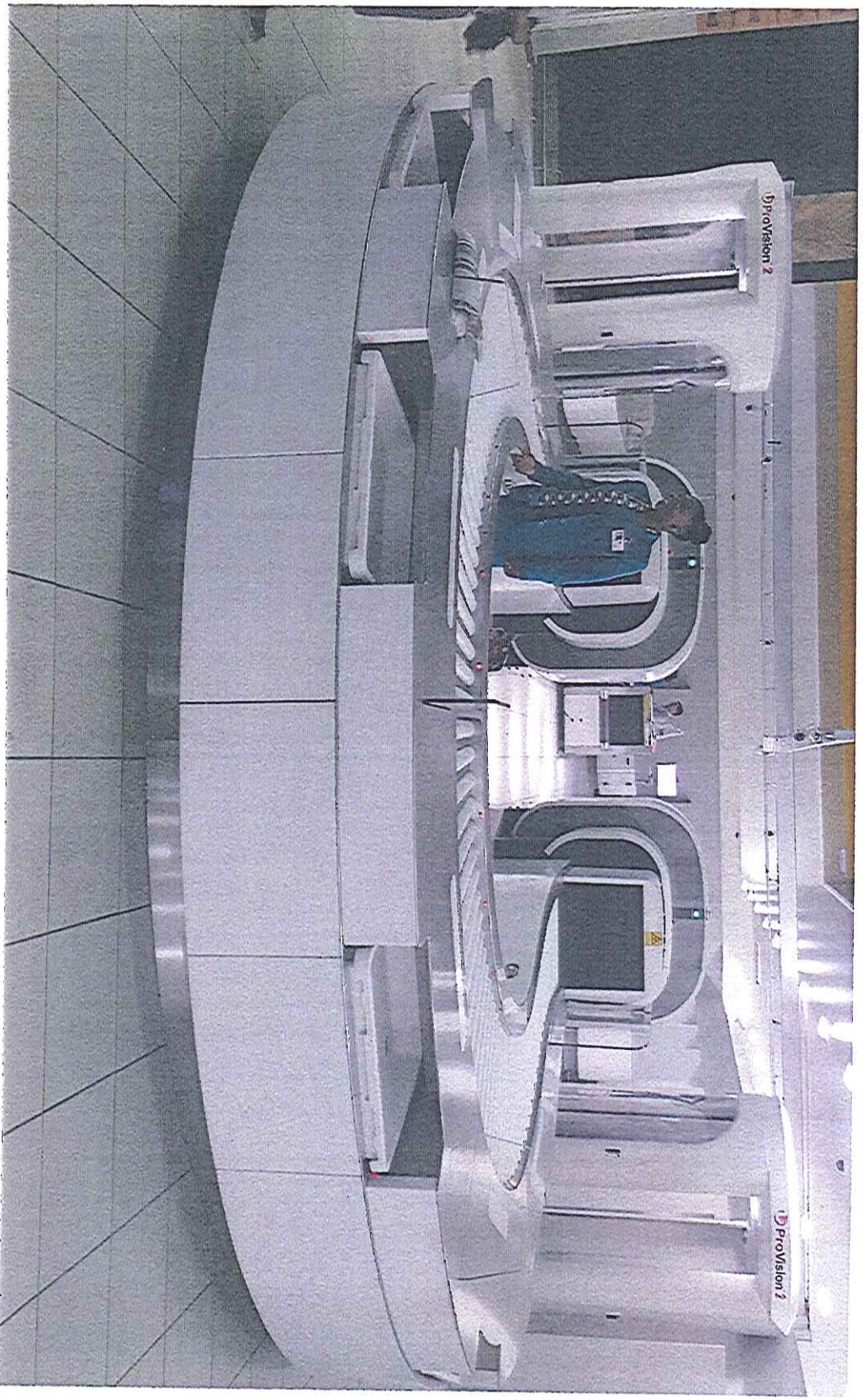

# SMART SECURITY



AIRPORTS COMPANY SOUTH AFRICA

31

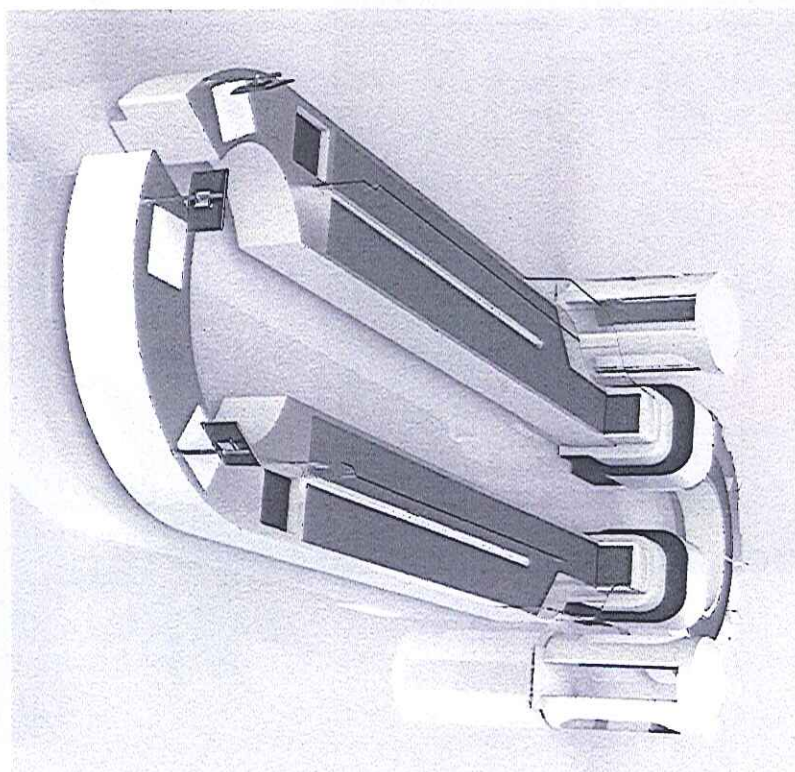
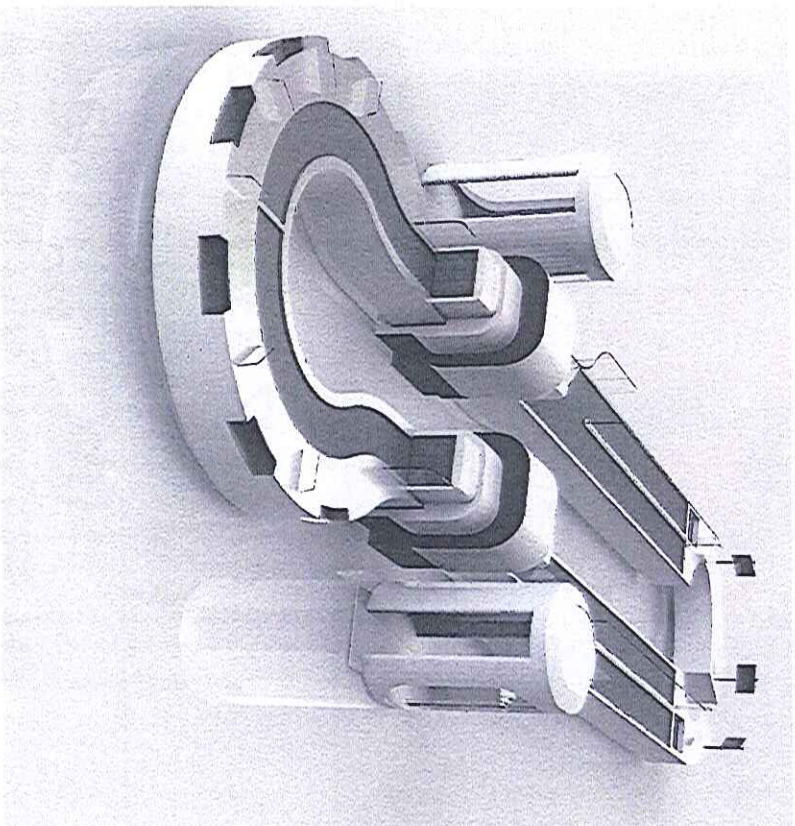

**RESTRICTED ACCESS TO  
FRONTAGE ROAD –  
BY NO LATER THAN 1  
SEPTEMBER 2017**



AIRPORTS COMPANY SOUTH AFRICA

Drive effective  
awareness  
campaign





# RESTRICTED ACCESS TO FRONTAGE ROAD - BY NO LATER THAN 1 SEPTEMBER 2017

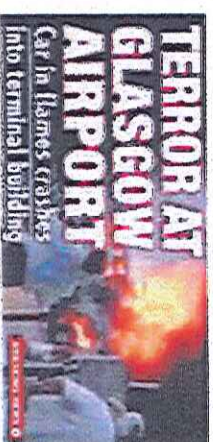
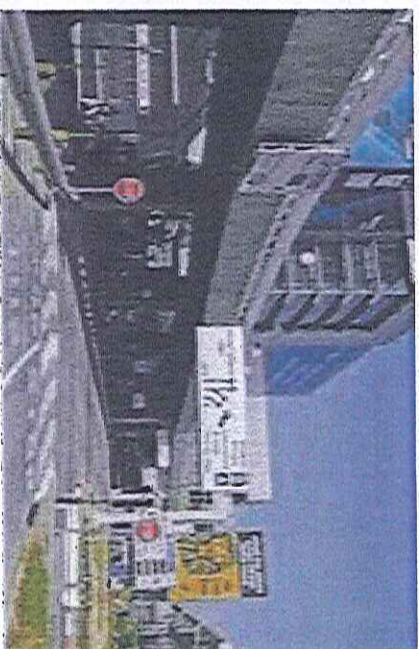



# BRUSSELS - 2016



## Brussels airport

### 22 march 2016

Salah Abdeslam, most wanted terrorist

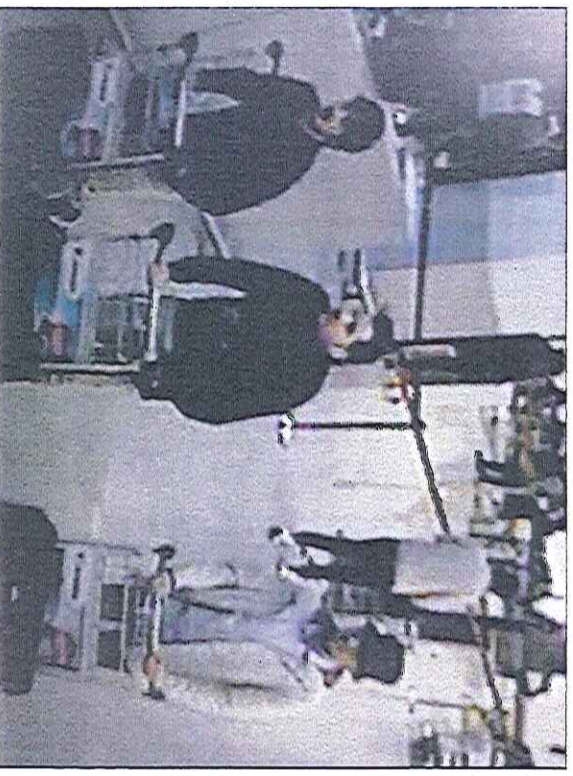

Suspected suicide bombers



# MULTI-DISCIPLINARY INTEGRATED TACTICAL SECURITY PLAN - OPERATIONAL STRUCTURE

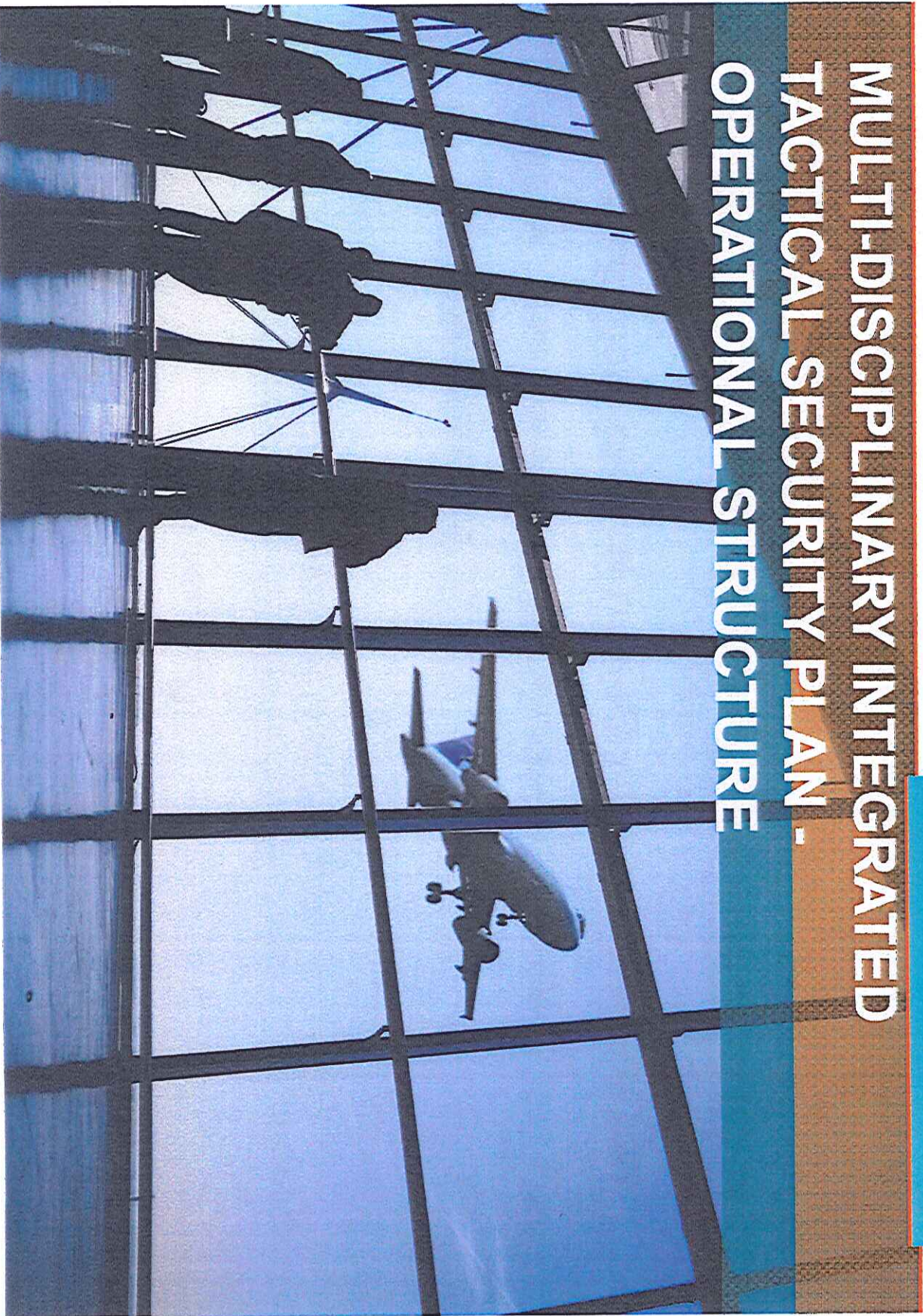

# OPERATIONAL

## STRUCTURE

*An effective operational response structure has been put in place so as to support the successful implementation of the Multi-Disciplinary Integrated Tactical Security Plan.*

- JOC - Joint Operations Centre
- JOCCOM - Joint Operations Centre Committee Meeting (daily)
- Extended JOCCOM - Chaired by Lt-General Mawela and takes place every Wednesday
- A 24 hour JOC has been established at the Airport to implement, support and monitor the plan. A Major-General (Ndaba) has been appointed to oversee the implementation of this plan.
- Major-General Ndaba chairs the daily JOCCOM meeting which includes all relevant Law Enforcement and Government departments.





# MEASURES OF SUCCESS

## WHAT NEXT?

- Resources
- Equipment
- Tools of Trade
- Timelines

## CRITICAL SUCCESS FACTORS

- Visibility
- Real-time resolution
- Collaboration
- Co-operation
- Integration
- Support at all levels – Minister to Ops level)
- Consistency & sustainability
- Accountability & responsibility based on plan objectives
- Quarterly review to be done with Ministers and key stakeholders
- Review next year together with Ministers – visit to other airports (as an example)



Collaboration

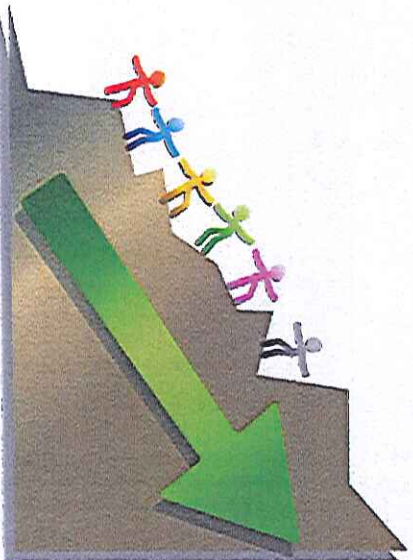

Co-operation



Integration

THANK YOU

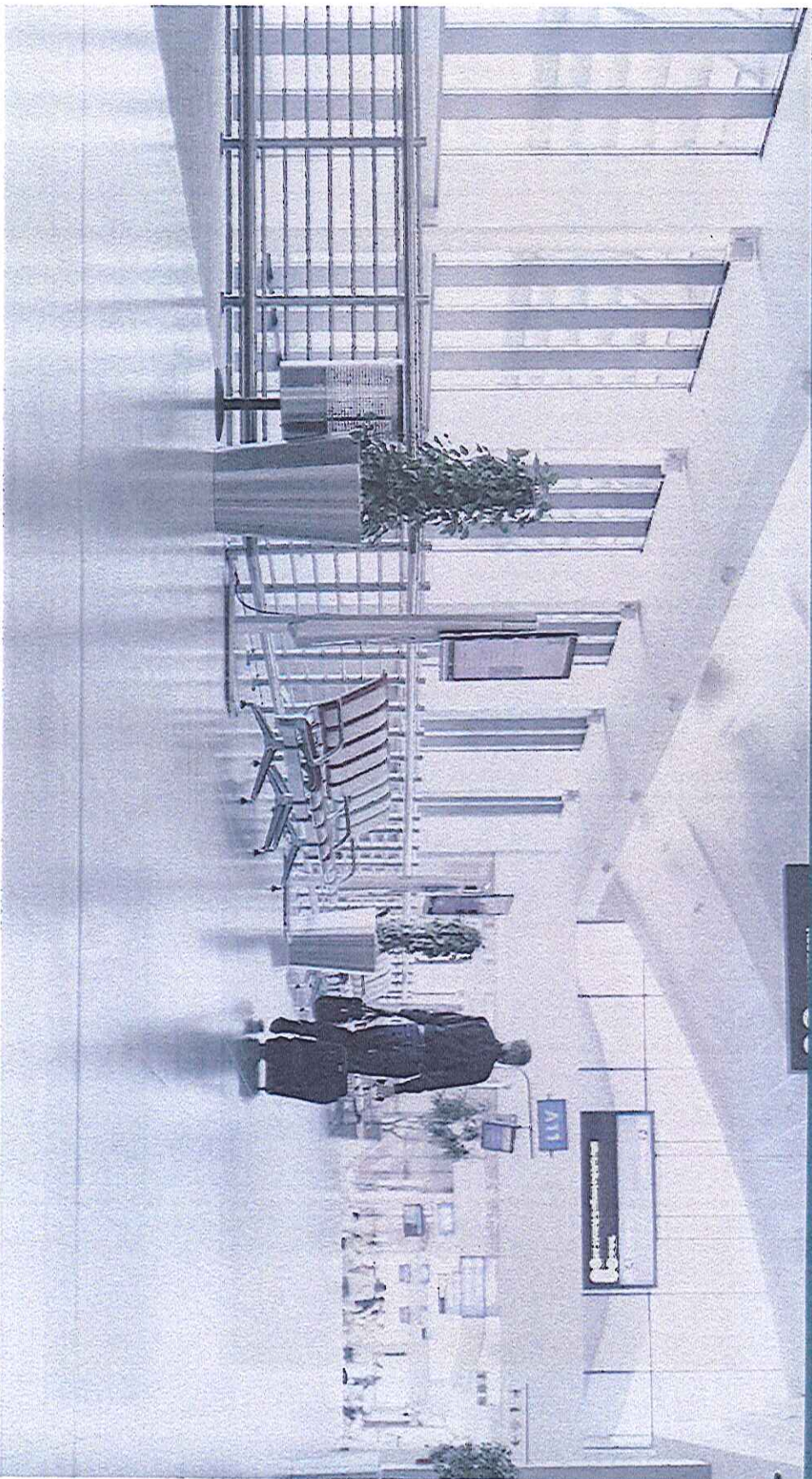



## DISCLAIMER

The information contained in this presentation is **confidential**, and is intended solely for this presentation. This presentation may contain information proprietary to the Airports Company South Africa SOC Limited (“the Company”), and may not be reproduced or disseminated in whole or in part without the Company’s written consent. The Company is not acting as your adviser in any transaction that may be proposed herein, and this presentation does not constitute a recommendation, guidance or proposal to enter into any transaction. Any decision to enter into a transaction should be made on the basis of information contained within an offering circular, programme memorandum or prospectus published in relation to such an offering. The Company does not guarantee or otherwise assure the expected results of any transaction as envisaged in this presentation. You shall not be entitled to place any reliance on the information contained in this presentation for the purposes of entering into any proposed transaction or otherwise.

